



**TELEDYNE OLDHAM SIMTRONICS**  
Everywhere you look™

## OLCT 80

Fixed Gas Detection



### Features

- Detectors-Transmitters for Flammable, Toxic Gases and Oxygen
- Non-intrusive operation via intrinsically safe infrared remote control
- Remote versions available XP, IS
- Integrated relays
- Direct link, 4-20 mA, loop and isolated sensor mode



# OLCT 80

Fixed Gas Detection

## Unique advantages providing the solution you need

### Design advantages

Pre-calibrated sensors for detection of:

- combustible gases: LEL catalytic and IR
- toxic gases
- oxygen

### Alarms

- 2 integrated gas alarms with relays
- 1 fault alarm with relay

### Inputs

Series 80 sensors have up to 9 glands dedicated to cable wiring Design advantages:

The minimum configuration includes:

- 1 electrical input dedicated to a sensor.
- two 4-20 mA or binary inputs. This configuration allows any other sensor from the network to be recognized (e.g temperature sensor, emergency stop, flame detector, smoke detector).

### Outputs

- 4/20 mA with smart signal processing
- analog signal 4-20 mA
- data signals between 0 and 4 - 20 and 25mA

The transmitted signal, between 0 and 3.2 mA and above 20 mA, can be processed to interpret and identify a wide range of trouble parameters such as: line faults, sensor faults, embedded electronics faults, ambiguity resolution, inhibition of calibration, maintenance call (initial drift or drift over time).

- RS485 (1200 bauds, 38kb Modbus ASCII for MX 62).

The RS485 link gives access to :

- sensor measurement
- status and default
- internal relay management

### Relays

The relays are 2A / 250 VAC type with potential free SPDT contacts.

### Two types of relays:

- 2 gas alarm relays or supplementary inputs
- 1 fault relay

The relays are actuated either

- directly by the sensor electronics or supplementary

inputs, or

- from the MX62 central unit or the control system to which the sensor is connected.

### The relays can be

- in safety mode or not,
- triggered on increasing or decreasing alarms,
- manually\* or automatically acknowledged.

\* By remote control, by pressing an external pushbutton connected to the dedicated binary input, by acknowledging on the MX 62 unit or the control system to which the sensor is connected.

### Alarms

- 2 integrated gas alarms with relays
- 1 fault alarm with relay

## Technical advantages

Stand-alone central unit

For relay control, the OLCT 80 can operate as a standalone unit: an indisputable advantage in a classified explosion risk zone.

### Flexibility of connection modes

OLCT 80 sensors can be connected either:

- in loop (opto-isolated - up to 16 sensors),
- 4-20 mA,
- under direct power and operate as a central unit.

### Operation traceability

The operator can check records locally for the most recent time-date stamped events.

### Communication

Remote dialogue with the sensor using IR remote control.

### Measurement power supply redundancy

Independent ports allow a redundant connection to the measurement unit.

### Low power requirements

The leading edge technology used in the OLCT80 transmitter makes it very energy efficient.

This major advantage means that more sensors can be connected, with smaller wire cross-sections and overgreater distances.

## Logistic advantages

### Loop arrangement

The transmitter is perfectly adapted to mounting and connection to the digital fieldbus loop of the MX 62 unit. Supporting 1 to 3 digital addresses:

- the sensor block (detection element),
- the two 4-20 mA auxiliary inputs.

## Certification

The OLCT80 Series is certified to the specifications required by standards EN 50054, 45544 and 50104 (environmental standards, explosive and toxic gases and oxygen) and to the specifications of standards EN 50270, EN 6052 (electromagnetic compatibility, ingress protection).

OLCT 80 uses digital logic and software technologies.

The sensors are protected and in compliance with the specifications of standard EN 51271:

- analog and digital values track each other
- homogeneity of digital resolution and response time with the specifications required
- internal self-diagnostics

# OLCT 80

## Fixed Gas Detection

Type of Gases	Type of sensor	Range (ppm)	Operating-temperature* (°C)	Relative humidity uncondensed	Pressure	Accuracy at full scale (at atmospheric pressure)	Life span (in months)	T (50)	IP	IS	AD
O <sub>2</sub>	electrochemical	30,00%	-20°C to +50°C	10% to 95% RH	Atm +/- 10%	from 5 to 30% = 0,4%vol	28	6	66	YES	YES
CO	electrochemical	100 300 1000	-20°C to +50°C	10% to 95% RH	Atm +/- 10%	+/- 2 ppm (range 0-100)	40	10	66	YES	YES
H <sub>2</sub> S	electrochemical	30 100 1000	10% to 95% RH	10% to 95% RH	Atm +/- 10%	+/- 1,5 ppm (between 0-30 ppm)	36	15	66	YES	YES
NO	electrochemical	100 300 1000	-20°C to +50°C	10% to 95% RH	Atm +/- 10%	+/- 2 ppm (range 0-100)	36	15	66	YES	YES
NO <sub>2</sub>	electrochemical	10 30.0	-20°C to +50°C	10% to 95% RH	Atm +/- 10%	+/- 0,8 ppm	24	20	66	YES	NO
	electrochemical	10.0 30.0 100	100 -10°C to +50°C	10% to 95% RH	Atm +/- 10%	+/- 0,7 ppm range 0-10	36	15	66	YES	NO
Cl <sub>2</sub>	electrochemical	10.0	-20°C to +50°C	10% to 95% RH	Atm +/- 10%	+/- 0,5 ppm	24	50	66	YES	NO
H <sub>2</sub>	electrochemical	2000	-20°C to +50°C	10% to 95% RH	Atm +/- 10%	+/-5 ppm range 0-100	24	50	66	YES	YES
HCl	electrochemical	30.0 100	-20°C to +40°C	10% to 95% RH	Atm +/- 10%	+/- 0,5 ppm range 0-10	24	50	66	YES	NO
HCN	electrochemical	1.0 30.0	-20°C to +40°C	10% to 95% RH	Atm +/- 10%	+/- 0,3 ppm range 0-10	18	40	66	YES	NO
NH <sub>3</sub>	electrochemical	100 1000	-20°C to +40°C	10% to 95% RH	Atm +/- 10%	+/- 5 ppm +/- 10 ppm range 0-1000	24	50	66	YES	YES
			-20°C to +40°C	10% to 95% RH	Atm +/- 10%						
O <sub>3</sub>	electrochemical	1,00	-10°C to +40°C	10% to 95% RH	Atm +/- 10%	+/-0,05 ppm	20	50	66	YES	NO
PH <sub>3</sub>	electrochemical	1,00	-20°C to +40°C	10% to 95% RH	Atm +/- 10%	+/- 0,05 ppm	18	40	66	YES	NO
ClO <sub>2</sub>	electrochemical	3,00	-20°C to +50°C	10% to 95% RH	Atm +/- 10%	+/- 0,3 ppm	24	50	66	YES	NO
SiH <sub>4</sub>	electrochemical	50	-20°C to +40°C	10% to 95% RH	Atm +/- 10%	+/- 1 ppm	18	40	66	YES	NO
AsH <sub>3</sub>	electrochemical	1,00	-10°C to +40°C	20% to 95% RH	Atm +/- 10%	+/- 0,05 ppm	18	40	66	YES	NO
CH <sub>4</sub>	catharometre	0-100%vol	-20°C to +50°C	10% to 95% RH	Atm +/- 10%	1% vol	60	5	66		
H <sub>2</sub>	catharometre	0-100%vol	-20°C to +50°C	10% to 95% RH	Atm +/- 10%	1% vol	60	5	66	YES	YES
NH <sub>3</sub>	catalytic	0-5000	-20°C to +50°C	10% to 95% RH	Atm +/- 10%	100 ppm	36	8	66	YES	YES
Flammable gas	catalytic	0-100% LIE	-20°C to +70°C	10% to 95% RH	Atm +/- 10%	1% LIE between 0- 60%LIE	60	5	66		
VOC	semi-conductor	500 ppm	-20°C to +50°C	10% to 95% RH	Atm +/- 10%	+/- 4 ppm if measure < 200 ppm	36	25	66	NO	YES
CO/H <sub>2</sub>	null	1000 ppm	-20°C to +50°C	10% to 95% RH	Atm +/- 10%	+/- 4 ppm if measure < 200 ppm	36	25	66	YES	YES
CO sensor						+/-20 ppm if measure>200 ppm				YES	YES

\* Temperature at 20°C and at Atmospheric Pressure

# Configuration Options

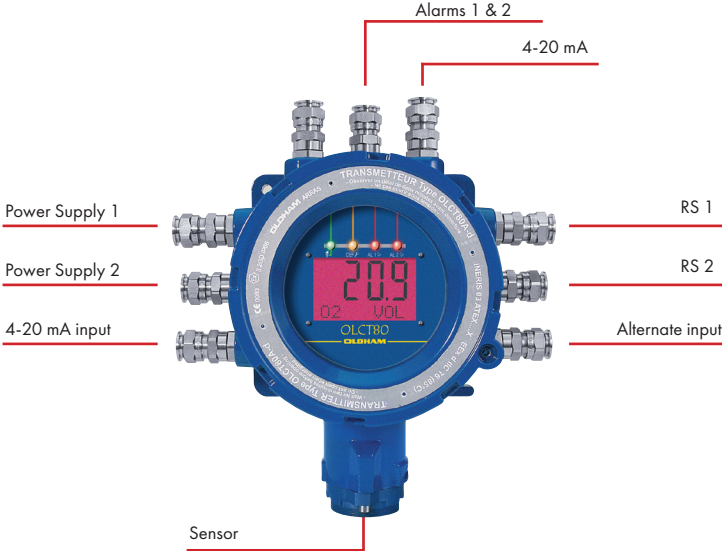

## Standard Version

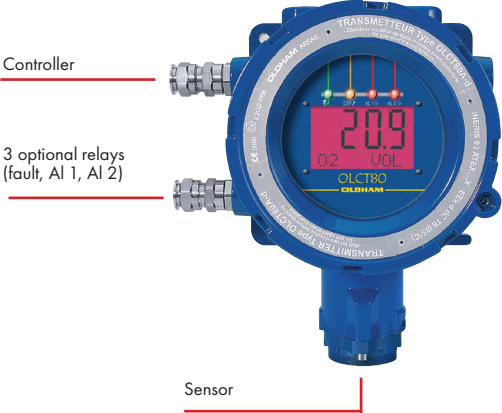

## Stand Alone Version

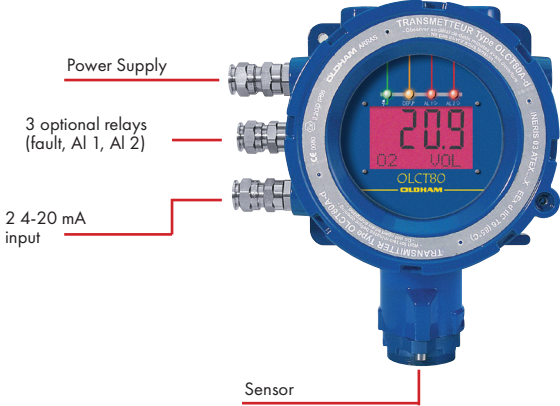

## Digital Version

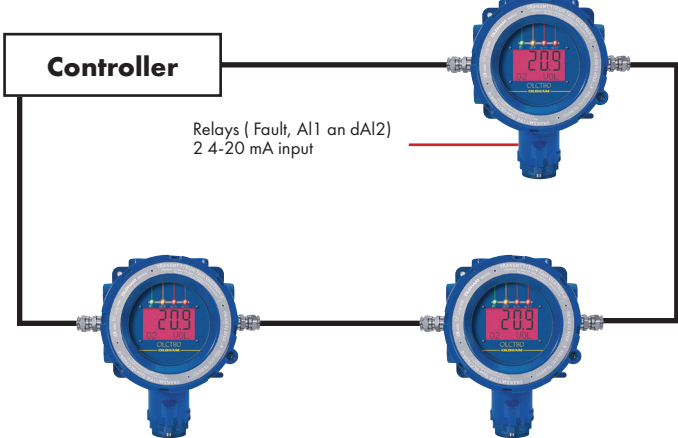

# OLCT 80

Fixed Gas Detection

## Specifications

Type	Transmitter-sensor
Detected gases	Explosive, toxic and oxygen
Detection principles	Catalytic, Electrochemical, IR, Semiconductor
Sensor block	Pre-calibrated
Device	Aluminium enclosure and stainless steel 316L for sensor housing
Visualisation	4-digit LCD display for measurement and one alphanumeric line for texts, Pictograms - backlighting 4 indicator lamps : one green : "OperationOK", one yellow : "Fault", red : "Alarm 1" and "Alarm 2"
Power supply	From 16 to 28 VDC at transmitter entry
Maximum power	with digital link - 0.2 W (electrochemical cell) - 1.3 W ( catalytic / SM ) with I output at 25 mA - 0.9 W (electrochemical cell) - 2 W ( catalytic / SM ) with I output at 25 mA and relays activated - 2.4 W (electrochemical cell) - 3.5 W ( catalytic / SM )
Power supply to sensor terminals	Two independent inputs : 16 to 28 VDC (catalytic / IR / SM cells) 12 to 28 VDC (electrochemical cell)
Inputs	Two analog inputs 4-20 mA (load resistance 120 $\Omega$ , can be used as binary)

## Signal outputs

Logic (relay contacts):	Relay
Analog:	Standardised 4-20 mA output
Digital:	Two independent opto-isolated RS 485 ports
Signal faults:	I < 0.5 mA
Alarms	2 programmable thresholds per channel

## Relays

Type	SPDT
Number	3
Contact	RCT changer-over
Breaking capacity	2A / 250 VAC / 30 VDC
Wiring / connection:	Basic version, 6 inputs : 4 M20 and 2 M25 On request : 3 additional, 2 M20 and 1 M25
Load resistance on the 4-20 mA	500 $\Omega$
Loop resistance	Under central unit 21 VDC: 128 ohms ( electrochemical cell ) - 32 $\Omega$ ( catalytic / SM ) - 16 $\Omega$ (IR)
Protection number	IP 66
Operating temperatures	- 20 °C to + 60 °C ( electronics, see table for detection cells )
Dimensions	See drawings
Weight	OLCT 80 : 3,5 kg      OLCT80 version IR : 5,3 kg

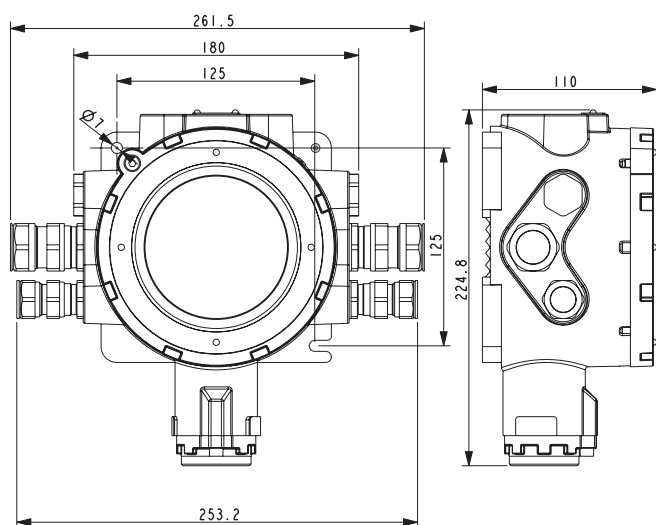

## Accessories

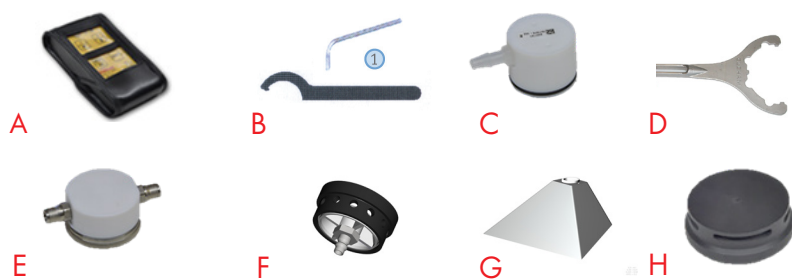

- |                           |                                  |
|---------------------------|----------------------------------|
| A Infrared remote control | E Calibration cup                |
| B Tool kit                | F Remote gas introduction device |
| C Bypass adapter          | G Gas collector                  |
| D Cover key               | H Splash guard                   |

## Homologations

### Certification Atex

OLCT 80 d	OLCT 80 id
ATEX II 2GD	ATEX II 2GD
Ex d IIC T6...T5 Gb	Ex d ia IIC T4 Gb
Ex tb IIIC T85°C...T100°C Db	Ex tb ia IIIC T135°C Db
INERIS 03ATEX0240X	INERIS 03ATEX0240X

### Chine

OLCT 80 d	OLCT 80 id
GYJ17.1201X - Ex d IIC T6/ T5 Gb	GYJ17.1202X - Ex d ia IIC T4 Gb

### Electromagnetic compatibility

Complies with EN 50270

# OLCT 80

Fixed Gas Detection



*Teledyne Oldham Simtronics quality assurance programmes demand the continuous assessment and improvement of all our products. Information in this leaflet could thus change without notification and does not constitute a product specification. For more information, please contact us or your company representative.*

## AMERICAS

14880 Skinner Rd  
Cypress, TX 77429  
USA  
Tel.: +1-713-559-9200  
Fax: +1 281-746-3064

## EMEA

ZI Est, Rue Orfila,  
CS 20417  
62027 ARRAS Cedex, France  
Tel.: +33-3-21-60-80-80  
Fax.: +33-3-21-60-80-00

## ASIA PACIFIC

Room 04, 9th Floor,  
275 Ruiping Road, Xuhui District-  
People's Republic of China  
Tel.: + 86-134 8229 5057

