



**TELEDYNE**  
**OLDHAM SIMTRONICS**  
Everywhere you look™

## OLCT 200

Universal Gas Detector



# OLCT 200

## Universal Gas Detector

### A gas detector for all your needs

The OLCT 200 offers a range of sensors and features that allow it to meet all your gas detection needs. The OLCT 200 comes in a 2-wire loop powered version for all electrochemical toxic and oxygen sensors, and a 3-4-wire version for catalytic bead and infrared combustible gas sensors, infrared carbon dioxide sensors, photo-ionization (PID) sensors, as well as electrochemical toxic and oxygen sensors. Universal design allows easy configuration of the OLCT 200 to different sensor types and configurations.

The OLCT 200 universal electronics allow any of the 3-4-wire versions to be equipped with relays, RS-485 Modbus, HART, or isolated 4-20mA outputs. In addition, all 3-4 wire toxic/oxygen, IR, & PID versions come standardly with the Arctic Heater allowing sensor operation down to -45°C/-49°F. With the ability to swap these components in the field it is possible to stock one transmitter type with different modules and sensors and configure the unit as needed for installation in the field. This feature eliminates the need to stock individual gas transmitters and can reduce inventory costs.



OLCT 200 with dual sensor option

### Easy Installation, Operation, and Maintenance

The OLCT 200 design allows ease of installation with easy to wire electrical connections and two 3/4" NPT openings to allow power, signal, and alarm wiring access. User interface is through four magnetic switches so that no special electronic tools are required for programming. These switches also allow calibration and programming functions to be performed without the need to declassify an area. The modular electrical design of the OLCT 200 allows easy upgrades at purchase or after installation to upgrade the transmitter to include functions such as relays, RS-485 Modbus, HART, and isolated 4-20mA output.

Operating OLCT 200 transmitters is simple and intuitive. The menu is easily accessible and gives clear instructions on accessing a variety of functions such as zero, calibration, alarm set point changes, and display backlight.

The OLCT 200 in 3-4-wire configuration can also take one electrochemical toxic or oxygen sensor and one catalytic bead, PID or infrared sensor. This allows greater flexibility in monitoring a location without the need for separate transmitters for two gas types.



Remote PID, Catalytic Bead, or Infrared Sensor

## OLCT 200 sensor connections available

- Integral sensor with transmitter (electrochemical, PID, catalytic bead, or infrared)
- Remote PID, catalytic bead or infrared sensor (100' maximum)
- Remote electrochemical sensor utilizing 4-20mA connection
- Dual integral sensors with transmitter (One electrochemical and one PID, catalytic bead or infrared)
- Dual sensors with integral electrochemical and remote PID, catalytic bead or infrared sensors (100' maximum)
- Dual sensors with remote electrochemical sensor utilizing 4-20mA connection and remote PID, catalytic bead or infrared sensor (100' maximum)

## OLCT 200 adapters available

- Calibration Adapter
- Splash Guard with Remote Calibration
- Sample Flow Cell

## OLCT 200 mounting adapters

- Pole Mounting Kit
- Duct Mounting Kit - PVC
- Duct Mounting Kit - Stainless Steel

## OLCT 200 Gas sensor & range list

### Electrochemical Sensors

- Ammonia (NH<sub>3</sub>) 0-100 ppm
- Ammonia (NH<sub>3</sub>) 0-300 ppm
- Carbon Monoxide (CO) 0-100 ppm
- Carbon Monoxide (CO) 0-500 ppm
- Chlorine (Cl<sub>2</sub>) 0-10.0 ppm
- Hydrogen Chloride (HCl) 0-30.0 ppm
- Hydrogen Cyanide (HCN) 0-30.0 ppm
- Hydrogen Sulfide (H<sub>2</sub>S) 0-50.0 ppm
- Hydrogen Sulfide (H<sub>2</sub>S) 0-100 ppm
- Nitrogen Dioxide (NO<sub>2</sub>) 0-10.0 ppm
- Oxygen (O<sub>2</sub>) 0-25% volume
- Sulfur Dioxide (SO<sub>2</sub>) 0-30.0 ppm

### Catalytic Bead Sensors

- Hydrogen (H<sub>2</sub>) 0-100% LEL
- Methane (CH<sub>4</sub>) 0-100% LEL
- Pentane (C<sub>5</sub>H<sub>12</sub>) 0-100% LEL

### Infrared Sensors (IR)

- Carbon Dioxide (CO<sub>2</sub>) 0-5.00% Vol
- Methane (CH<sub>4</sub>) 0-100% LEL
- Propane (C<sub>3</sub>H<sub>8</sub>) 0-100% LEL

### Photo-Ionization Sensors (PID)

- VOC's 0-25 ppm
- VOC's 0-300 ppm

# OLCT 200

## Universal Gas Detector

### Specifications and ordering information

#### OLCT 200 specifications

Enclosure	Transmitter: Epoxy Coated Aluminum (NEMA 7, 3/4" NPT Cable Entries) Sensor Housing: 316 Stainless Steel
Weight	6.5 lbs (2.95 kg) without accessories (single sensor)
Approvals	CSA Approved for use in Class I, Division 1, Group A-D Locations: Catalytic, Infrared, PID, & Electrochemical (except NH3 & Cl2).
Power Supply	2-Wire: 10-30VDC at less than 0.75 watts; 3-Wire: Power Input 10-30VDC at < 6.5 watts with relays energized
Display	Backlit 64 x 128 pixel LCD with 30-minute trend, bar graph and engineering units display, 3 LED's A1, A2, F
Channel 1 Input	Electrochemical toxic and oxygen sensors / 4-20ma current input
Channel 2 Input	Catalytic Bead, Infrared and Photoionization sensor (10.6 eV) / 4-20mA current input
Standard Output	4-20mA
Optional Outputs	RS-485 Modbus, HART, Isolated 4-20mA, (3) 5 amp relays SPDT
Operating Temperature	Catalytic Bead Sensors: -40°F to 140°F/-40°C to 60°C Electrochemical, Infrared (IR) and Photo-Ionization (PID) Sensors: -49°F to 140°F/-45°C to 60°C
Ingress Protection	NEMA 4X, IP66
Dimensions	5.0" (127mm) W x 7.8" (197mm) H x 5.1" (130mm) D (Outline Drawings Below)

Single Sensor Housing

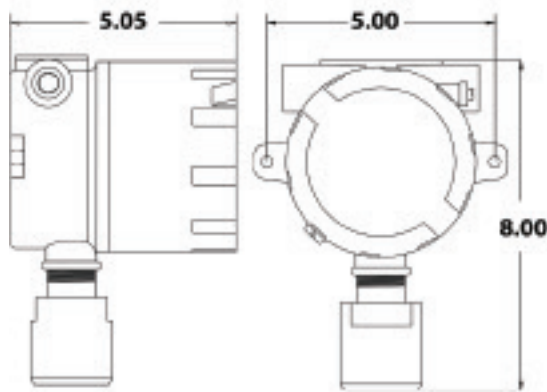

Dual Sensor Housing

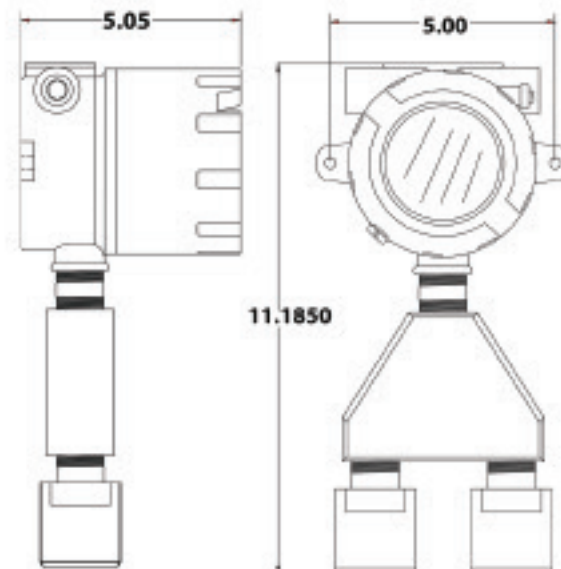

ALL DIMENSIONS IN INCHES

Teledyne Gas & Flame Detection quality assurance programmes demand the continuous assessment and improvement of all our products. Information in this leaflet could thus change without notification and does not constitute a product specification. For more information, please contact us or your company representative



**AMERICAS**  
14880 Skinner Rd  
Cypress, TX 77429  
USA  
Tel.: +1 713-559-9200

**EMEA**  
ZI Est, Rue Orfila,  
CS 20417  
62027 ARRAS CEDEX, France  
Tel.: +33-3-21-60-80-80

**ASIA PACIFIC**  
Room 2722, No. 51 Jinzang Road,  
China (Shanghai) Pilot Free Trade  
Zone, China  
Tel.: +86-134 8229 5057