

P2000

Continuous Emission Monitoring (CEMS/AMS) Process Analyser



Overview

P2000 is an infra-red (IR), duct or stack-mounted Analyser, designed to provide In-Situ analysis of up to six gas-phase emission components.

A typical system comprises of a stack mounted Analyser, an integral Calibration Module and a Control Unit with options which include a powerful In-Situ Heater and a stand-alone Analysis Software package.

P2000 uses the reflective beam principle to directly measure process gas as it enters the in situ sample cell.

Unlike higher maintenance extractive systems, Protea's patented, sintered metal technology removes the need for gas filtering or sample conditioning.

The P2000 analyser requires very little maintenance and achieves a class-beating availability of over 98% in demanding applications.

The Control Unit can support multiple analysers from the Protea range.

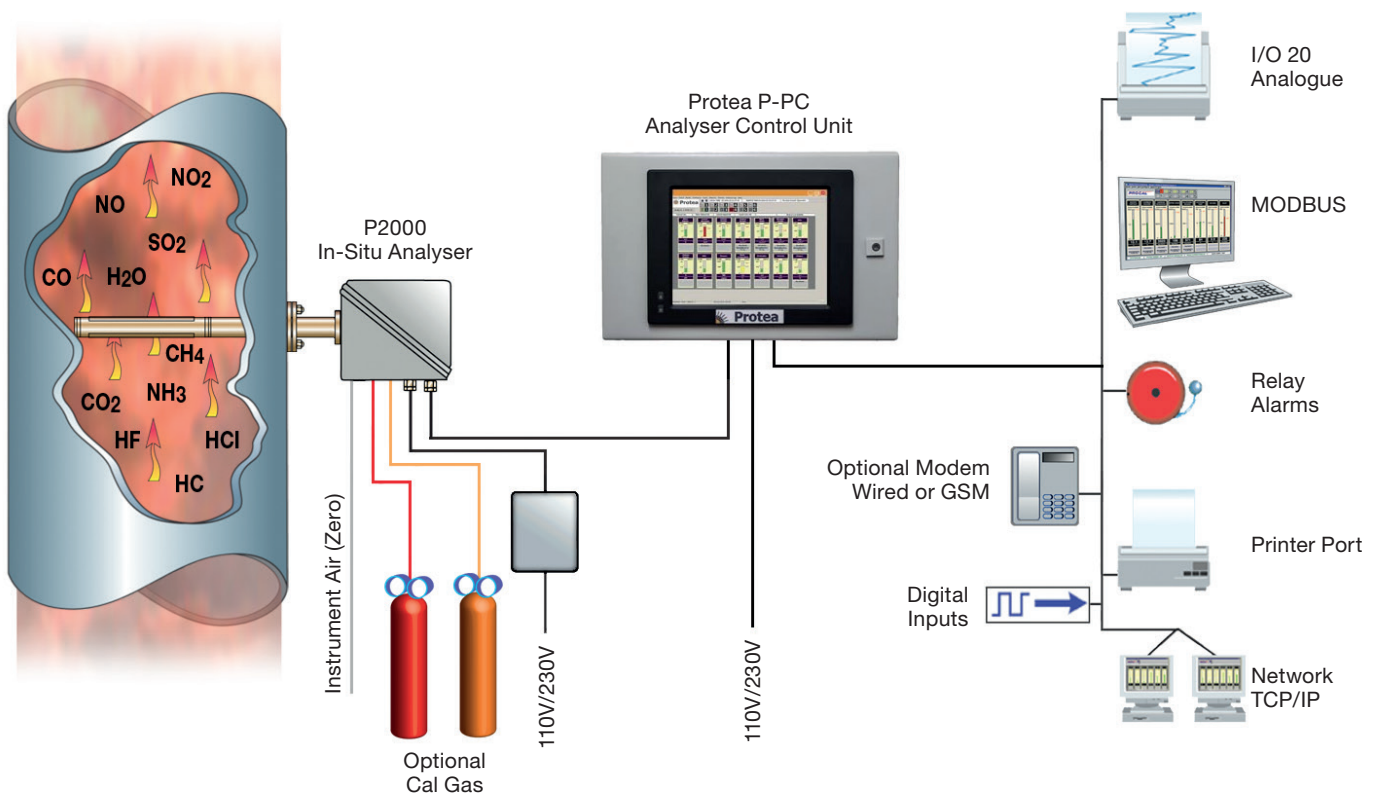

Examples of Principles of Operation

Analyser: The P2000 analyser operates on the proven, single beam, dual-wavelength IR principle. Mid IR Pulses, at two specific wavelengths per monitored component, are transmitted through the sample cell. The 'measure' pulse is partially absorbed by the gases being measured while the 'reference' pulse remains unaffected. Up to eight wavelengths are available, sometimes sharing reference wavelengths, allowing up to six gas-phase component concentrations

to be monitored simultaneously. Uniquely, the operation, zero and calibration are "fully challenged" in that all operating modes use the same optical path and system components.

Auto Verification: The integral Auto Verification Unit provides a zero-check on the system by filling the sample probe with clean, dry instrument air. Similarly, it performs a span-check by filling the sample probe with certified span gas.

Features	Benefits
Multi-component gas analysis	Each P2000 can measure up to six component
Direct in-situ measurements	No requirement for high cost, high maintenance sample handling system or sample conditioning
Protea's proven In-Situ Sinter Assembly	Long life stainless steel sinter 0.3um
Wet or dry readings	Can inherently report on Wet or Dry gas basis
Automatic signal verification and recalibration	No operator intervention during routine use
Oxygen or CO ₂ measurement normalisation (option)	Report measurement corrected to normalised O ₂ or CO ₂ reference conditions
Single Flange mounted analyser	Reduced cost and simplicity of installation
Low maintenance	Reduced cost of ownership
ATEX / IEC option	Can be used in hazardous areas
Marine approved	Suitable for marine applications
MCERTS approval	QA 1 Certified

Principle of operation:	Single Beam Dual Wavelength Infra Red with GFC where advantageous.
Gases measured:	Up to 6 hetero-atomic molecular gases as determined by the application.
CO	0 - 150ppm / 188mg/Nm ³
SO ₂	0 - 100ppm / 280mg/Nm ³
NO	0 - 240ppm / 322mg/Nm ³
CO ₂	0 - 15%
H ₂ O	0 - 20%

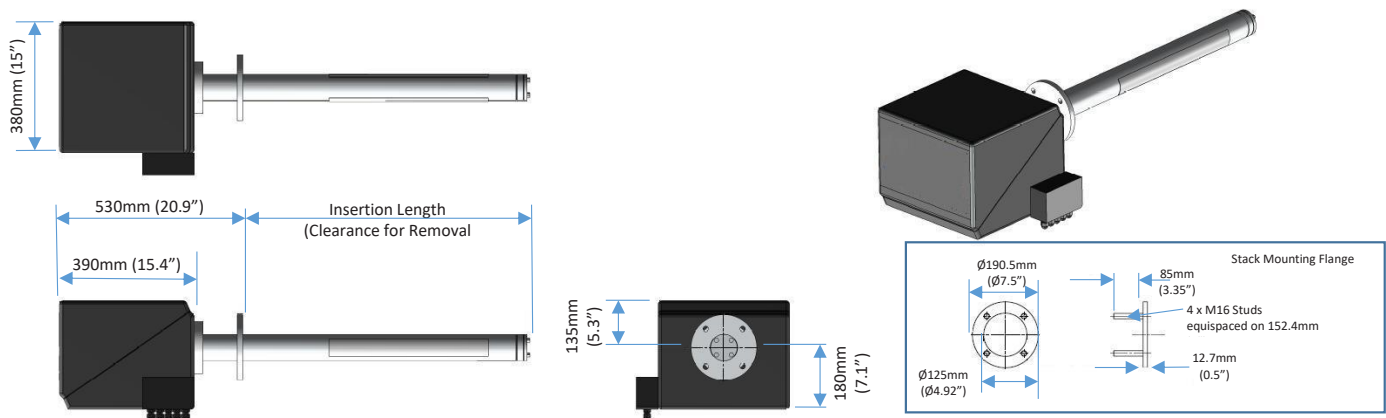

Control Unit Options

Analyser Control Unit – Protea P-PC

The Protea P-PC data logging and control system is Microsoft Windows based. The system is capable of controlling up to six, widely dispersed, Protea analysers of any design. The Protea P-PC range is also designed to accept signal I/O from other instruments in the

process to provide a single CEMS data hub. The Protea P-PC system displays gas concentrations and third party analyser I/O along with information on sample conditions, diagnostic data and trends. The information can also be made available to external devices in a variety of industry standard data protocols.



Examples of Monitoring Ranges

Spectral range:	Specific application dependent wavelengths (up to 8) are selected between 2-12 μm .
Infra-red source:	Enclosed nichrome filament.
Infra-red detector:	Solid state pyroelectric element.
Sample path length:	1 metre.
Sample temperature:	Up to 350°C (660°F). Optional higher temperatures up to 800°C (1742°F).
Cross-sensitivity:	Minimal due to the wavelength selection and advanced algorithms in the processor software.
Accuracy:	Typically $\pm 2\%$ of full scale concentration but dependent on application.
Response time:	Application dependent but typically 120 seconds to T90.
Enclosure:	Aluminium alloy casting with high protection finish, protected to IP65 (NEMA 4X).
Operating environment:	Operating temperature range -20°C to 55°C (-4°F to 130°F). Optional Analyser Cooler/Heater for greater temperature range.
Materials-contact with gas:	Calcium Fluoride, Glass, 316 Stainless Steel, Graphite.
Services required:	Power for analyser with PSU 115V/230V 175W. Power for in situ heater (optional) 115V/230V 1kW. Instrument air for the analyser void purge, auto zero and sample cell protection, controlled by the analyser, 2 barG; flow rate 0.5 litre/min constant and 6 litre/min intermittent during Auto-zero (typically 8 minutes every 12 hours).
Interconnection cable:	2 twisted-pair cores with individual screen typically allows up to 1000m separation between Analyser and Protea 1000 Analyser Control Unit.
Weight:	25 kg (46.3lb).
Physical dimensions:	Analyser 1360mm (53.5") x 380mm (15") x 315mm (12.4").

Optional Components

Optional accessories are available to extend the analyser's capability in cases of extreme process or ambient variations. Typical examples would be a probe heater to ensure the in situ gas cell operates above process gas dew point, a gas flow bypass for high sample applications analyser for operation in high ambient temperature conditions. Further details of these and many other accessories are available at www.protea.ltd.uk or on the accessories data sheet.

Approvals

Continuous Emissions Monitoring
CEM – US EPA 40 CFR part 60 & 75
AMS – Europe QAL 1 of EN 14181

The P2000 system is designed to meet the requirements of both customers and environmental authorities worldwide. The system enables rapid upgrades with regard to measuring range, presentation and reporting format, thus ensuring compliance with reporting criteria such as US EPA 40 CFR part 60 & 75 legislation. The system calculates errors due to drift in Zero and Span gas calibration suitable for use as input data to external EN14181 QAL 3 reports.



This Datasheet is a guide to the product and Protea Ltd reserve the right to modify the product without notification.